

Major Specifications

- * Type : MDSB-1411N
- * Measuring depth : -0.1 to +33.015m
- * Wind-up speed : 42 m/min.
- * Wind-down speed : 42 m/min.
- * Detecting weight : 140kg
- * Wire rope : dia.14 x 7/37 (SUS304)
- * Link chain : dia.16 x 0.5m (SUS304)
- * Motor source : AC380V 50Hz
- * Circuit source : AC220V 50Hz
- * Brake source : DC24V

FOR REFERENCE ONLY

批准番号 REV. No.	変更日付 REV. DATE
変更者 REVISED	承認 APPROVED
内容 REMARKS	

Mass : 1000kg

Flange JIS10K-400A FF

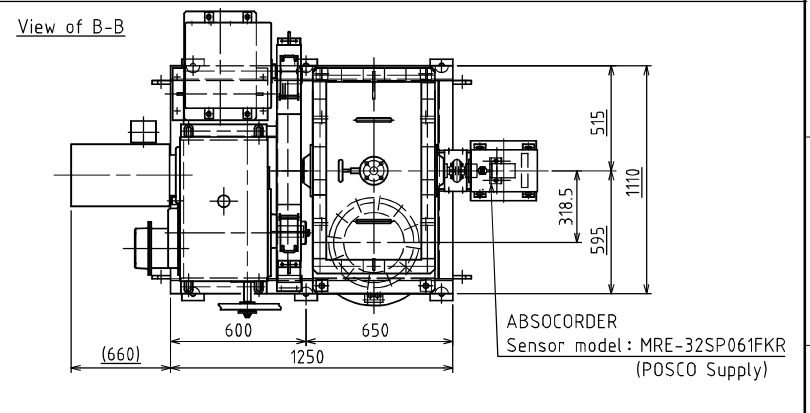

	尺度 SCALE 1:20	作成日付 DATE Oct. 5, 2012	承認 APPROVED H. Shigeeda	名称 TITLE DIMENSION DIAGRAM OF SOUNDING DEVICE
	単位 UNITS mm	製図 DRAWN D. Inoue	確認 CHECKED K. Nakamura	

	図面番号 DRAWING NO. S31A0052	REV. No.
	Matsushima Measure Tech	