

Sounding-V

Compact type level meter for powder storage level up to 20m.
Precisely measures the storage level in powder silo or tank and displays in remote indication.



Features

- **Anyone can use it easily**
Only set switch to measure storage level.
- **Adjustment is unnecessary**
It is controlled automatically by micro computer.
- **Auto-operation of storage tank by one Sounding V unit is possible.**
Outputs the measured value by DC4~20mA signal.
- **It can measure the powder level correctly**
Guaranteed accuracy within 1%(from 2 m to 20 m).
- **Automatic measurement is also available**
It is equipped with an 8 step switching timer from 1 to 60 minutes.
- **Durability is excellent**
Casing and the main parts are of FRP resin.
- **Installation is easy**
Only mount on the JIS 10 K 4 B flange to complete installation.
- **Countermeasures to problems are perfect**
If trouble occurs, an alarm signal is outputted immediately.
- **Power is AC 100V**
Worked by single phase power (both 50/60Hz)
(power consumption 30 VA)

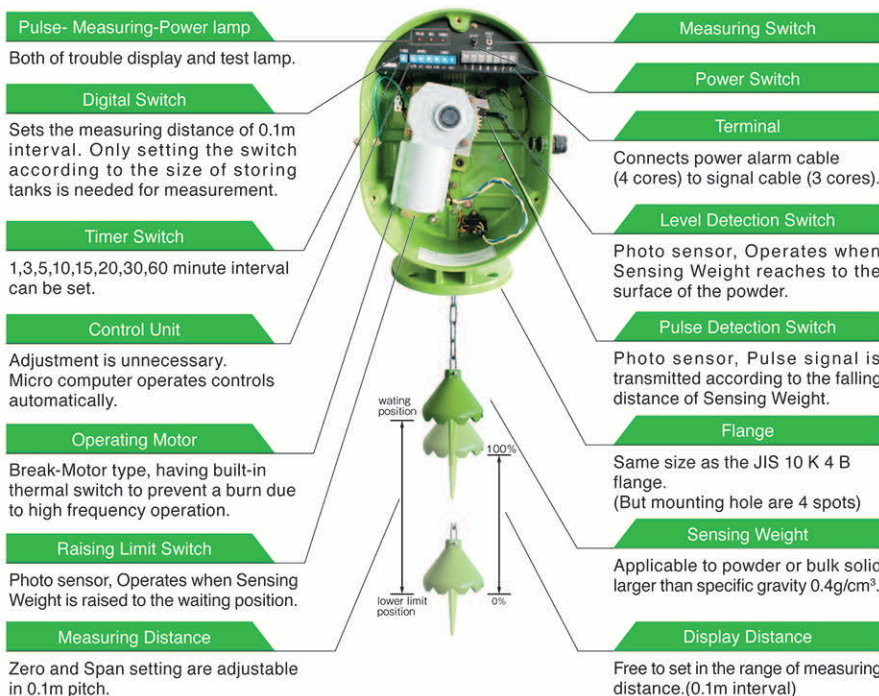

<Option>

■ Current Indicator(option)

Input signal: DC4~20mA
Meter Relay is available for substitute.
110mm / square
4~20mA DC
0~100% scale
coating color
munsel N 1.5



■ Sensing Weight

material : SUS 304
weight : 1.2kg
Equipped with
SUS 304 type connection chain.



Standard Specification

Type	MDVC-2S2 type	Sensing Weight	1.2kg(Volume gravity of object is more than 0.4g/cm ³)
Wire rope	φ2mm (SUS304) strength 3.5kN (358kgf)	Operating motor(25W)	All closing form condenser motor, B-type isolation, permanent brake, special rank thermal protector built in (return itself type)
Measuring distance	0~20m		
Measuring accuracy	1% F.S. of	Main parts materials	exterior, flange, drum : FRP resin wire rope : SUS 304 sounding lead : FC 200 sounding lead chain : SS 400 drum axis, pulley axis : S 35 C•S 15C roll top detection lever : SS 400
Output signal	DC4~20mA load resistance : 350Ω or less		
Traveling speed	8.8/10.5m/min (50/60Hz)		
Measuring signal	One measurement by instantaneous ON (adove 0.1 sec) Auto measurement with internal timer by continuous ON		
Automatic Measuring	1,3,5,10,15,20,30,60min intervals	Power spurce	AC90~120V 50/60Hz (30VA)
Measuring frequency	Max.50% ED(continuous measurement is possible when the measuring time is equal to or less than the pausing time.)	Ambient temperature	-10°C ~ +50°C
		Protection	IP55 against pressure case ± 1.96kPa
Alarm	Alarm contact turns ON when rope is cut and motor is over loaded.	Coating color	Munsell 7.5GY 6/10
		Weight	12kg(included Sensing Weight)

Specifications

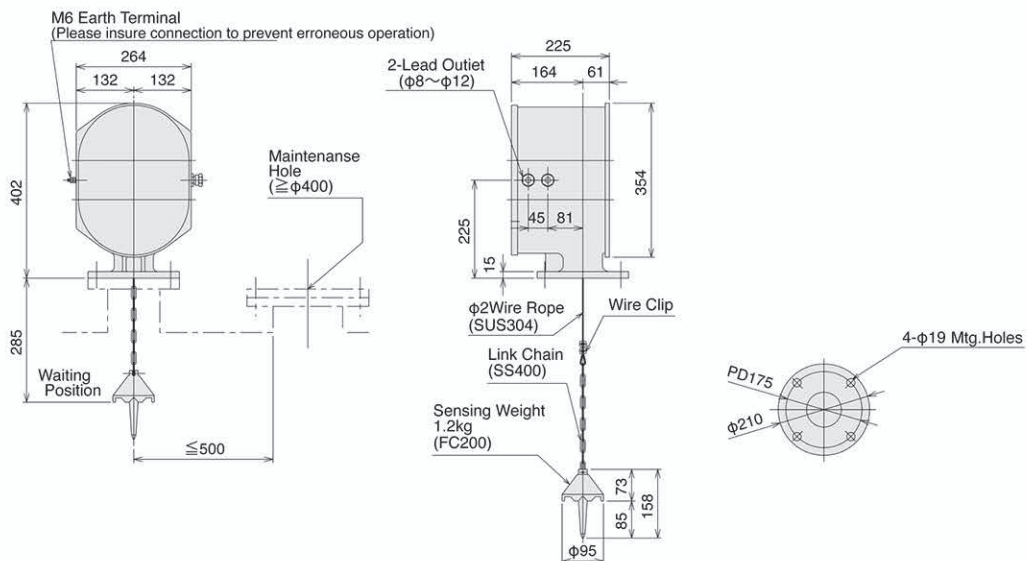

Connection Diagram

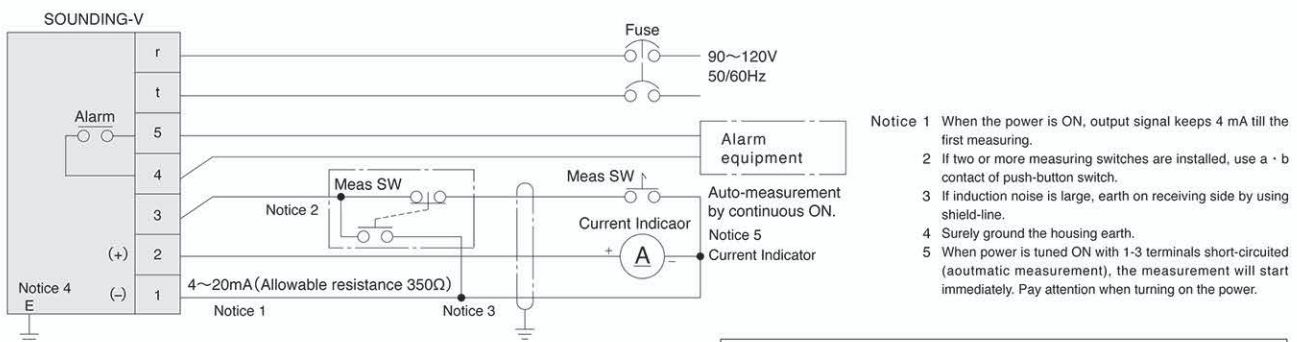

Specifications are subject to change without notice.
All Rights Reserved Copyrights©2017, Matsushima Measuretech Co., Ltd.



Caution
 • Read the instructions to ensure correct and suitable application of products.
 • Contact our nearest sales office when using our products for any systems used in situations which may be life threatening.

Distributor



Matsushima Measure Tech Co., Ltd.

HEAD OFFICE
 1-8-18, NORIMATSU-HIGASHI, YAHATANISHI-KU, KITAKYUSHU, 807-0837 JAPAN
 Tel: +81-93-691-3731 FAX: +81-93-691-3735
 http://www.matsushima-m-tech.com E-mail: info@matsushima-m-tech.com

Pohang Representative Office
 Odyssey Bldg, 1F, 41, Jukdo-ro 28beon-gil, Buk-gu, Pohang-si, Gyeongsangbuk-do, 791-841, korea
 Tel: +82-(0)54-274-3731 FAX: +82-(0)54-274-3731

Affiliated company
 Shanghai Dahong Matsushima Machinery Co., Ltd.
 70 Hengchang Road, Dahong, Malu, Jiading, Shanghai 201818, China
 Tel: +86-(0)21-5951-4138 FAX: +86-(0)21-5951-4139